

ROE
CREATIVE DISPLAY



TOPAZ 2.6

High-Performing Efficiency

Indoor LED panel

Topaz TP2.6: The All-purpose Live Events LED Panel

Are you looking for a cost-effective LED panel with trusted ROE Visual quality? Topaz fits that bill seamlessly. With its high-precision mechanics and excellent visual quality, it offers everything you love about ROE Visual. Topaz is a LED panel that combines stable and reliable performance with affordable cost-of-ownership, playing into the market challenges of AV-rental companies.



The road-ready rental panel

Topaz offers excellent visual quality in a sturdy frame that assembles with the precision and ease you're accustomed to – just like all ROE Visual LED panels. Topaz is easy to hang or stack, allowing for seamless installations that foster creativity in stage design.



Don't sacrifice quality

There's no need to balance quality or specs against your return on investment. Topaz offers the best of both worlds, a cost-efficient LED panel with a high utilization potential. Topaz allows you to lower your initial investment without sacrificing quality.





Pixel pitch 2,6



Lightweight panel design



Unleash Creativity with Exceptional Visuals

Experience the brilliance of the Topaz LED panel, designed to captivate with its 2.6 pixel pitch and vibrant colors. This indoor LED solution is a cost-effective marvel, ideal for various applications including.

Modular design
PSU and HUB
combined in one unit



High-brightness,
1500 nits



Front and rear
module service



Cost-efficient

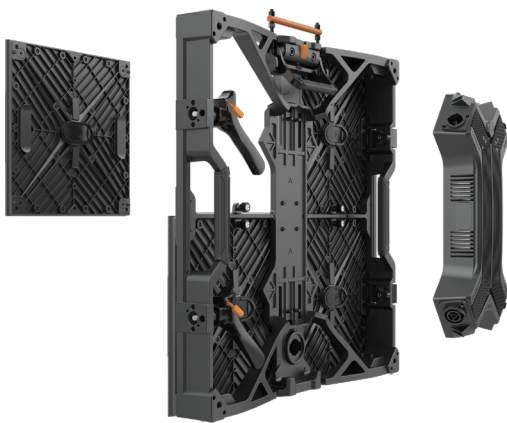

Your Daily Workhorse

Maintenance is a breeze with the Topaz panels, featuring both front and rear module service. The integrated PSU and Hub unit streamline repair and spare part replacement, making maintenance easy and cost-effective.

More information on:
www.roevisual.com/topaz



Specifications

Tile	Topaz 2.6
Pixel Pitch	2.604mm
LED Configuration	SMD 1515 Black
Max Brightness Calibrated	1500nits
Panel Dimension	500 x 500 x 73mm, 19.7" x 19.7" x 2.87"
Panel Resolution (H x V)	192 x 192
Weight Per Panel	8.4kg; 18.52lbs
Power Consumption Max/Average	190W / 95W
BTU Max/Average ^{BTU}	650/300
Transparency	Solid
Serviceability	Front / Rear
Curving (Concave & Convex)	Concave 5°-Convex 3°
Max. Hanging panels ^{*1}	20
Max. Stacking panels ^{*2}	12
Viewing Angle Vertical	140°
Viewing Angle Horizontal	140°
Scan Ratio	01/16
Refresh Rate	3840Hz
Gray Scale	16bit
Frame Material	Magnesium Alloy
Operational Temp/Humidity	-20°- 45°C, 10-90% RH / -4°-113°F, 10-90% RH
IP Rating	Indoor
Certifications	CE, ETL, FCC, RoHs

The specifications are for reference, actual values may vary.

*Note:

*1 The max. hanging amount is only valid when the ROE Visual hanging bar and complementary accessories are used and in an indoor situation, safety factor is 8. No climbing is allowed.

*2 The max. stacking amount is only valid when the ROE Visual stacking system and complementary accessories are used, sufficient ballast is applied and in an indoor situation. No climbing is allowed.

*3 Convex curving ability only applies to custom tiles.

Dimensions

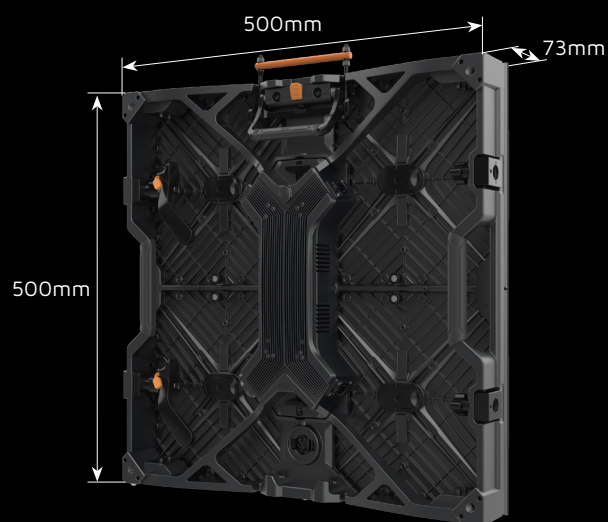

www.roevisual.com

ROE China | ROE US | ROE EU | ROE UK | ROE JP | ROE ME
roe@roevisual.com